

DRIVABLE GRASS® CONCRETE MAT

INFILL TURF WITH #30 SAND UP TO 1/4" BELOW SURFACE. LARGER COLORED PARTICLE INFILLS CAN BE USED STARTING AFTER INITIAL #30 INFILL 1/2" BELOW SURFACE.

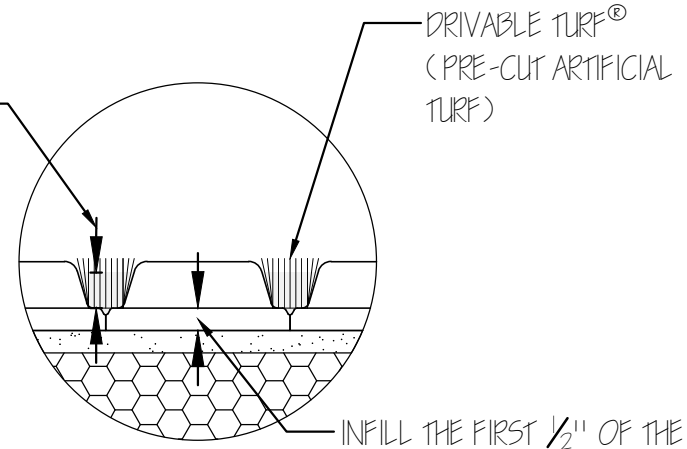

INFILL DETAIL  
 INFILL THE FIRST 1/2" OF THE DRIVABLE GRASS® MATS WITH BEDDING OR #30 SAND.

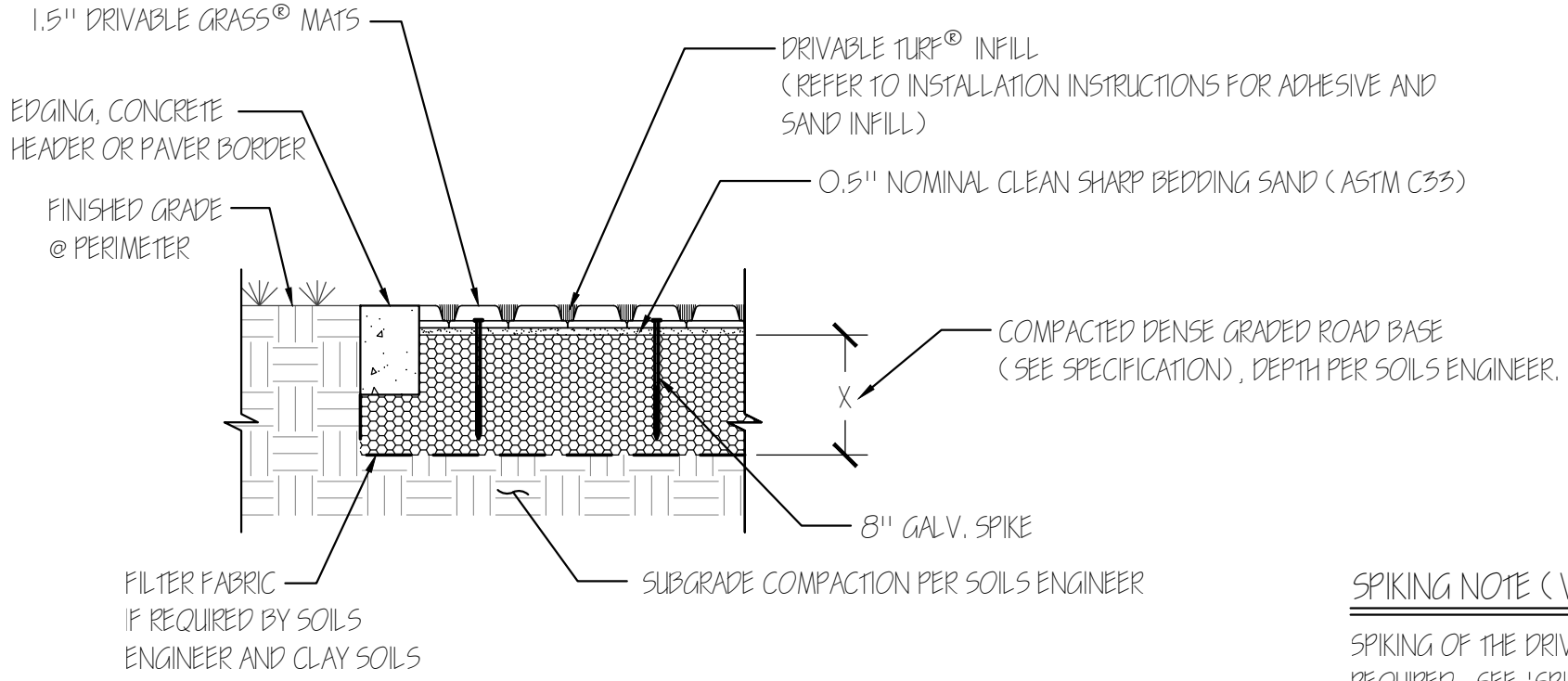

TYPICAL PROFESSIONAL DRIVABLE GRASS® DETAIL WITH DRIVABLE TURF® INFILL

SCALE: 1" = 1'

SPIKING NOTE (VEHICULAR DRIVING):  
 SPIKING OF THE DRIVABLE GRASS® MATS IS REQUIRED. SEE 'SPIKING DETAIL'.



PROTECTED BY US AND INTERNATIONAL PATENTS AND TRADEMARKS